



FLOATING

SELF-CLINCHING

FASTENERS

BULLETIN



ALA

505

Revised 406

FLOATING* SELF-CLINCHING FASTENERS

Locking and Non-locking Threads

These fasteners provide load-bearing threads in thin sheets and permit up to .030 inches / 0.8 mm adjustment for mating hole misalignment.

The self-clinching feature offers fast and simple assembly. The fasteners are squeezed into punched or drilled holes using any standard press. The sheet remains flush on one side, and the fastener is permanently locked in place.

Extra strength and support in assembly is obtained by the threads of the floating nut extending fully into the retainer shank (a unique PEM feature). A self-locking version of the fastener is also offered. Uniformity of locking torque is equivalent to NASM25027 specifications.

** Many PEM Type AS and AC self-clinching floating fasteners correspond to sizes in US NASM45938/11 specifications. Consult our Marketing department for a complete Military Specification and National Aerospace Standards Reference Guide (Bulletin NASM) or check our web site.*

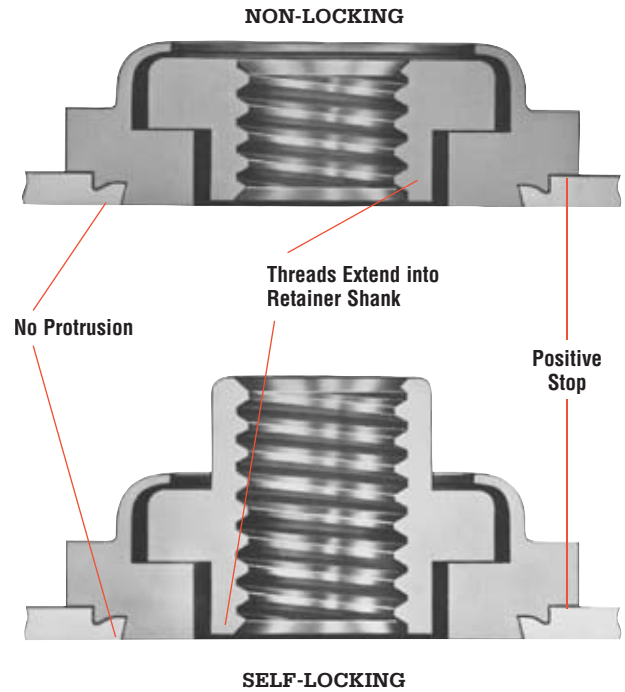

Double squares are a registered trademark

Always look for the square insert in a square retainer to be sure you are getting PEM brand fasteners and the best in self-clinching performance.

Bottom view (same for both type fasteners)

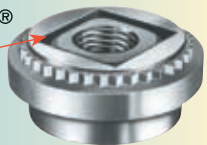

Part Number Designation

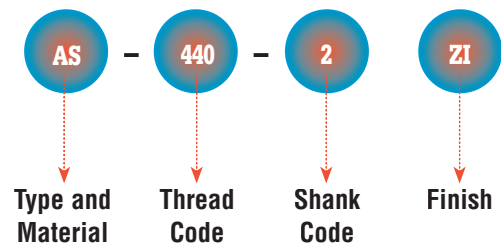

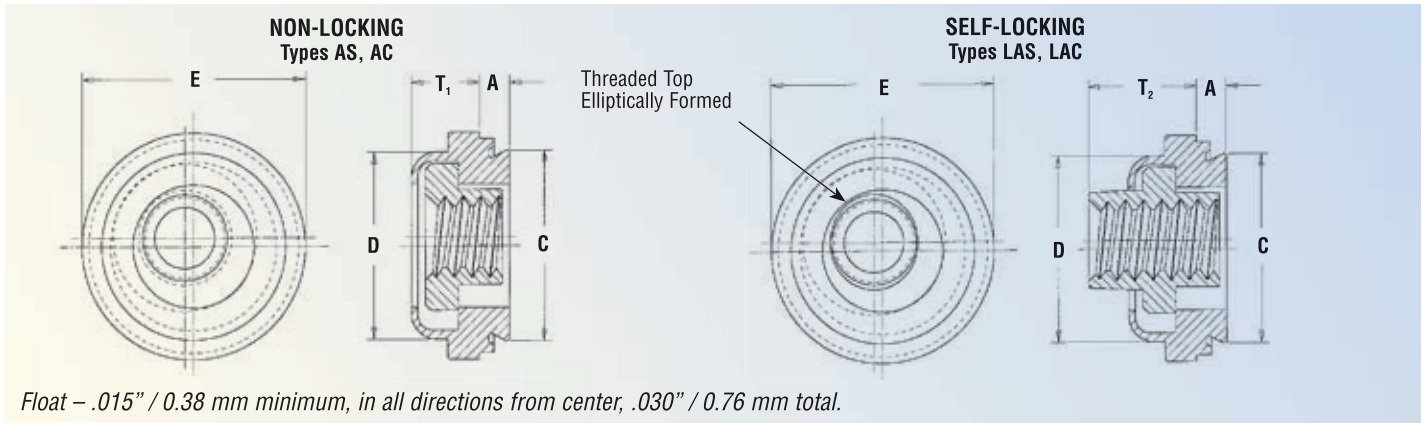

Float – .015" / 0.38 mm minimum, in all directions from center, .030" / 0.76 mm total.

All dimensions are in inches.

UNIFIED	Thread Size	Type				Thread Code	Shank Code	A (Shank) Max.	Min. Sheet Thickness	Hole Size in Sheet + .003 - .000	C Max.	D Max.	E ± .015	T ₁ Max.	T ₂ Max.	Min. Dist. Hole C/L To Edge
		Non-Locking		Self-Locking												
		Fastener Material		Fastener Material												
		Steel	Stainless Steel	Steel	Stainless Steel											
.112-40 (#4-40)	AS	AC	LAS	LAC	440	1	.038	.040	.290	.289	.290	.36	.13	.19	.30	
						2	.054	.056								
.138-32 (#6-32)	AS	AC	LAS	LAC	632	1	.038	.040	.328	.327	.335	.39	.13	.20	.32	
						2	.054	.056								
.164-32 (#8-32)	AS	AC	LAS	LAC	832	1	.038	.040	.368	.367	.365	.44	.13	.21	.34	
						2	.054	.056								
.190-24 (#10-24)	AS	AC	LAS	LAC	024 ^{NS}	1	.038	.040	.406	.405	.405	.47	.17	.27	.36	
						2	.054	.056								
.190-32 (#10-32)	AS	AC	LAS	LAC	032	1 ^{NS}	.038	.040	.406	.405	.405	.47	.17	.27	.36	
						2	.054	.056								
.250-20 (1/4-20)	AS	AC	LAS	LAC	0420	2	.054	.056	.515	.514	.510	.60	.21	.31	.42	
.250-28 (1/4-28)	AS	AC	LAS	LAC	0428 ^{NS}	2	.054	.056	.515	.514	.510	.60	.21	.31	.42	

NS Not Stocked, available on special order.

All dimensions are in millimeters.

METRIC	Thread Size x Pitch	Type				Thread Code	Shank Code	A (Shank) Max.	Min. Sheet Thickness	Hole Size in Sheet + 0.08	C Max.	D Max.	E ± 0.4	T ₁ Max.	T ₂ Max.	Min. Dist. Hole C/L To Edge
		Non-Locking		Self-Locking												
		Fastener Material		Fastener Material												
		Steel	Stainless Steel	Steel	Stainless Steel											
M3 X 0.5	AS	AC	LAS	LAC	M3	1	0.97	1	7.37	7.35	7.37	9.14	3.31	4.83	7.62	
						2	1.38	1.4								
M4 X 0.7	AS	AC	LAS	LAC	M4	1	0.97	1	9.35	9.33	9.28	11.18	3.31	5.34	8.64	
						2	1.38	1.4								
M5 X 0.8	AS	AC	LAS	LAC	M5	1	0.97	1	10.31	10.29	10.29	11.94	4.32	6.86	9.14	
						2	1.38	1.4								
M6 X 1	AS	AC	LAS	LAC	M6	2	1.38	1.4	13.08	13.06	12.96	15.24	5.34	7.88	10.67	

MATERIAL & FINISH SPECIFICATIONS

Type	Threads		Fastener Materials				Standard Finishes				Optional Finishes				For Use In Sheet Hardness			
	Non-locking, Internal ANSI B1.1, 2B/ANSI/ASME B1.13M, 6H	Self-locking, Internal ANSI B1.1, 3B/ANSI/ASME B1.13M, 6H	Heat-Treated Carbon Steel	300 Series Stainless Steel	300 Series Carbon Steel	Zinc per ASTM B 633 SC1 (5µm), Type III, Colorless	Zinc per ASTM B 633 SC1 (5µm), Type II, Colorless	Passivated and/or tested per ASTM A380	Passivated and/or tested per ASTM A380	Passivated and/or tested per ASTM A380	Black Dry-film Lubricant	Passivated and/or tested per ASTM A380	Black Dry-film Lubricant per MIL-PRF-46010 over Cadmium Chromate Prime	Zinc per ASTM B 633 SC1 (5µm), Type II, Colorless		Black Dry-film Lubricant per MIL-PRF-46010 over Cadmium Chromate Prime	Passivated and/or tested per ASTM A380	Black Dry-film Lubricant per MIL-L-46010 over Silver
AS	•		•		•												•	
AC	•			•					•								•	
LAS		•	•		•	•								•			•	
LAC		•		•						•			•				•	
Part number codes for finishes						ZI	None		MD		F		ZF		SF			

INSTALLATION

1. Punch or drill the properly sized mounting hole in sheet. Do not perform any secondary operations such as deburring.
2. Place fastener into the anvil hole and place the mounting hole over the shank of the fastener.
3. With the punch and anvil surfaces parallel, apply sufficient squeezing force until flange contacts mounting sheet. Sketch at right shows suggested tooling for applying these forces. Installation force and performance data shown below.

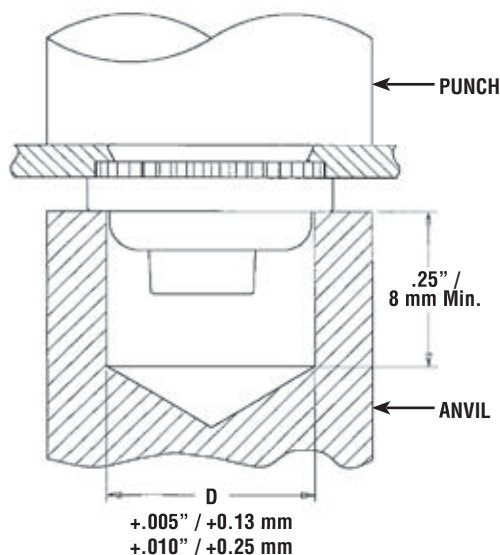

PERFORMANCE DATA⁽¹⁾

UNIFIED	Thread Code	Shank Code	Test Sheet Material								
			2024-T3 Aluminum			5052-H34 Aluminum			Cold-Rolled Steel		
			Installation (lbs.)	Retainer Pushout (lbs.)	Retainer Torque-out (in. lbs.)	Installation (lbs.)	Retainer Pushout (lbs.)	Retainer Torque-out (in. lbs.)	Installation (lbs.)	Retainer Pushout (lbs.)	Retainer Torque-out (in. lbs.)
440	1	3000	220	65	1500	215	65	3000	300	85	
	2		225	150	2000	225	80			150	
632	1	3000	235	110	2000	240	140	3000	300	150	
	2		275	150		250	150			175	
832	1	3000	240	110	2000	250	140	3000	300	150	
	2		300	150		265	150		400	200	
032	1	3500	300	150	2000	300	150	3500	400	150	
	2			200		350	175		450	200	
0420	2	5000	300	325	3000	400	325	5000	500	325	
0428											

METRIC	Thread Code	Shank Code	Test Sheet Material								
			2024-T3 Aluminum			5052-H34 Aluminum			Cold-Rolled Steel		
			Installation (kN)	Pushout (N)	Retainer Torque-out (N•m)	Installation (kN)	Pushout (N)	Retainer Torque-out (N•m)	Installation (kN)	Pushout (N)	Retainer Torque-out (N•m)
M3	1	2	13.3	978	7.3	6.7	956	7.3	13.3	1334	9.6
	2		13.3	1000	16.9	8.9	1000	9	13.3	1334	16.9
M4	1	2	13.3	1067	12.4	8.9	1112	15.8	13.3	1334	16.9
	2		15.6	1334	16.9	8.9	1178	16.9	13.3	1779	22.6
M5	1	2	15.6	1334	16.9	8.9	1334	16.9	15.6	1779	16.9
	2		16.6	1334	22.6	8.9	1556	19.7	15.6	2001	22.6
M6	2	2	22.2	1334	36.7	13.3	1779	36.7	22.2	2224	36.7

(1) The installation, pushout and retainer torque-out values reported are averages when all installation specifications and procedures are followed. Variations in mounting hole size, sheet material and installation procedure will affect this data. Performance testing of this product in your application is recommended. We will be happy to provide samples for this purpose.

RoHS compliance information can be found on our website.

Specifications subject to change without notice.
Check our website for the most current version of this bulletin.

PennEngineering®



North America: Danboro, PA 18916 USA • E-mail: info@pemnet.com • Tel: +1-215-766-8853 • Fax: +1-215-766-0143 • 800-237-4736 (USA Only)
U.K. And Europe: Doncaster, England • E-mail: uk@pemnet.com Tel: +44 (0)1302 765700 • Fax: +44 (0)1302 367580
Asia/Pacific: Singapore • E-mail: singapore@pemnet.com • Tel: +65-6-745-0660 • Fax: +65-6-745-2400
Shanghai, China • E-mail: china@pemnet.com • Tel: +86-21-5868-3688 • Fax: +86-21-5868-3988

Visit our PEMNET™ Resource Center at www.pemnet.com

CAGE-46384