

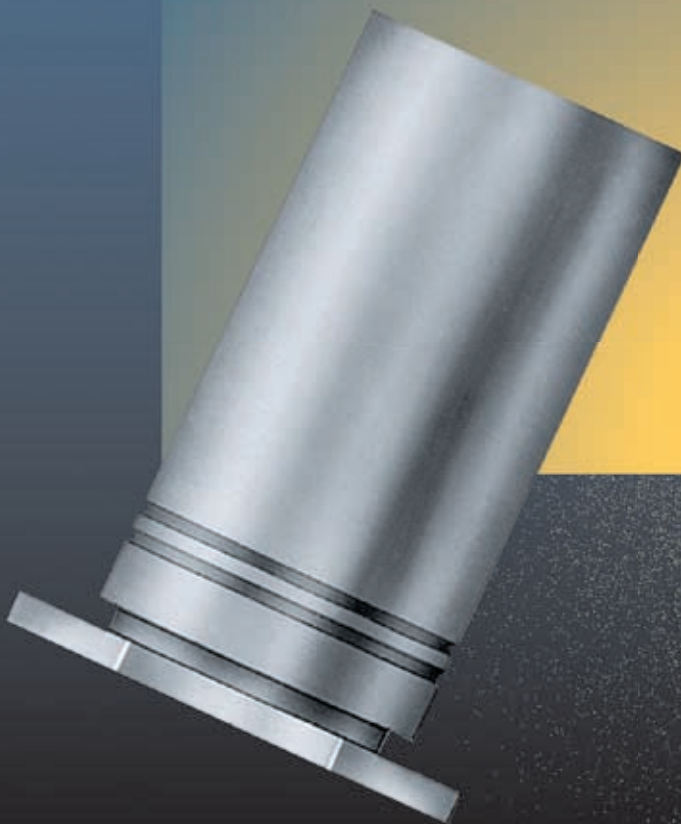

SELF-CLINCHING

STANDOFFS

BULLETIN



SO

305

Revised 406

SELF-CLINCHING STANDOFFS

These standoffs, which use the proven self-clinching design, install with a squeeze in punched or drilled round holes – and become permanently mounted in the thin sheet.

PEM® brand thru-hole threaded standoffs (**Page 5**) are installed with their heads flush with one surface of the mounting sheet. When blind-threaded types (**Page 6**) are used, outer sheet surfaces are not only flush, but closed as well. Unthreaded standoffs (**Page 7**) are also available for spacing multi-panel assemblies.

Types SO4 and BSO4 standoffs (**Pages 3 and 4**) are for installation into stainless steel sheets as thin as .040" / 1.02 mm.

Types TSO, TSOS, and TSOA self-clinching threaded standoffs (**Page 8**) provide permanent threads in sheets as thin as .025" / 0.63 mm.

PEM® self-clinching standoffs are also available on special order in non-heat treated carbon steel as type SON (thru-hole threaded) or BSON (blind threaded).

Types DSO and DSOS standoffs (**Page 9**) are available for close-to-edge applications.

If you require a standoff which we do not offer in this bulletin, please contact us. We will be happy to work with you to satisfy your special need.

For other types of PEM® brand standoffs and spacers see:

- Bulletin CH** PEM® Concealed-head Standoffs.
- Bulletin K** PEM® Standoffs for printed circuit boards.
- Bulletin SK** PEM® KEYHOLE® Standoffs.
- Bulletin SMT** PEM® ReelFast™ SMT Spacers/Nuts.
- Bulletin SSA** PEM® brand SNAP-TOP® Standoffs.

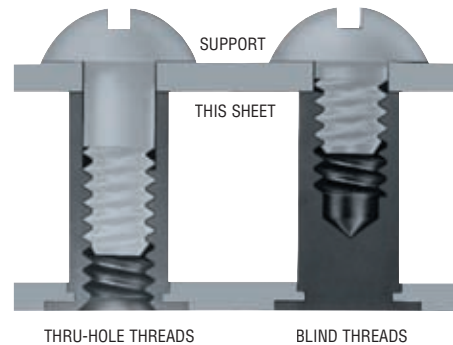

Part Number Designation

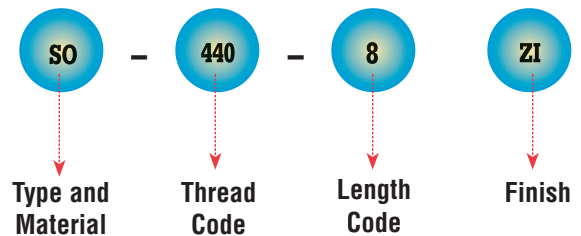

TYPE S04 THRU-HOLE THREADED STANDOFFS FOR INSTALLATION INTO STAINLESS STEEL

GENERAL DIMENSIONAL DATA

All dimensions are in inches.

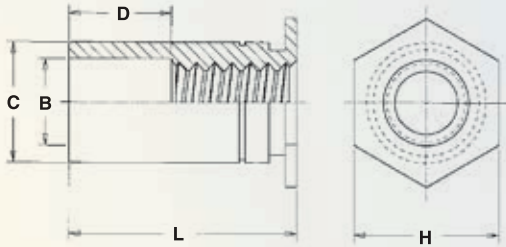

UNIFIED	Thread Code	Min. Sheet Thickness	Hole Size In Sheet +.003 -.000	B Counter-Bore Dia. ±.005	C +.000 -.005	H Nom.	Min. Dist. Hole C/L To Edge
	440	.040	.166	.125	.165	.187	.23
	6440	.040	.213	.125	.212	.250	.28
	632	.040	.213	.156	.212	.250	.28
	8632	.050	.281	.156	.280	.312	.33
	832	.050	.281	.188	.280	.312	.33
	032	.050	.281	.203	.280	.312	.33

All dimensions are in millimeters.

METRIC	Thread Code	Min. Sheet Thickness	Hole Size In Sheet +0.08	B Counter-Bore Dia. ±0.13	C -0.13	H Nom.	Min. Dist. Hole C/L To Edge
	M3	1.02	4.22	3.25	4.2	4.8	6
	3.5M3	1.02	5.41	3.25	5.39	6.4	7.1
	M3.5	1.02	5.41	3.9	5.39	6.4	7.1
	M4	1.27	7.14	4.8	7.12	7.9	8.4
	M5	1.27	7.14	5.35	7.12	7.9	8.4

THREAD SIZE AND LENGTH SELECTION DATA

All dimensions are in inches.

UNIFIED	Thread Size	Type	Thread Code	Length "L" +.002 - .005 (Length Code in 32nds of an inch)															
				.125	.187	.250	.312	.375	.437	.500	.562	.625	.687	.750	.812	.875	.937	1.00	1.062
	.112-40 (#4-40)	S04	440	4	6	8	10	12	14	16	18	20	22	24	N/A	N/A	N/A	N/A	N/A
			6440 ⁽¹⁾	4	6	8	10	12	14	16	18	20	22	24	26	28	30	32	34
	.138-32 (#6-32)	S04	632	4	6	8	10	12	14	16	18	20	22	24	26	28	30	32	34
			8632 ⁽¹⁾	4	6	8	10	12	14	16	18	20	22	24	26	28	30	32	34
	.164-32 (#8-32)	S04	832	4	6	8	10	12	14	16	18	20	22	24	26	28	30	32	34
			032	4	6	8	10	12	14	16	18	20	22	24	26	28	30	32	34
D Dimension ±.010				None				.187				.312				.437			

All dimensions are in millimeters.

METRIC	Thread Size x Pitch	Type	Thread Code	Length "L" +0.05 -0.13 (Length Code in millimeters)															
				3	4	6	8	10	12	14	16	18	20	22	25				
	M3 x 0.5	S04	M3	3	4	6	8	10	12	14	16	18	N/A	N/A	N/A				
			3.5M3 ⁽¹⁾	3	4	6	8	10	12	14	16	18	20	22	25				
	M3.5 x 0.6	S04	M3.5	3	4	6	8	10	12	14	16	18	20	22	25				
			M4	3	4	6	8	10	12	14	16	18	20	22	25				
			M5	3	4	6	8	10	12	14	16	18	20	22	25				
D Dimension ±0.25				None				4				8				11			

(1) Standoffs with thread codes 6440, 8632, and 3.5M3 offer greater wall thickness for thread sizes 440, 632, and M3 respectively.
(N/A) Not Available.

Please contact your local PEM® distributor for availability, minimum quantity, and pricing information.

TYPE BSO4 BLIND THREADED STANDOFFS FOR INSTALLATION INTO STAINLESS STEEL

GENERAL DIMENSIONAL DATA

All dimensions are in inches.

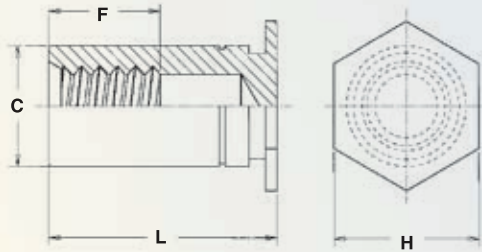

UNIFIED	Thread Code	Min. Sheet Thickness	Hole Size In Sheet +.003 -.000	C +.000 -.005	H Nom.	Min. Dist. Hole C/L To Edge
	440	.040	.166	.165	.187	.23
	6440	.040	.213	.212	.250	.28
	632	.040	.213	.212	.250	.28
	8632	.050	.281	.280	.312	.33
	832	.050	.281	.280	.312	.33
	032	.050	.281	.280	.312	.33

All dimensions are in millimeters.

METRIC	Thread Code	Min. Sheet Thickness	Hole Size In Sheet +0.08	C -0.13	H Nom.	Min. Dist. Hole C/L To Edge
	M3	1.02	4.22	4.2	4.8	6
	3.5M3	1.02	5.41	5.39	6.4	7.1
	M3.5	1.02	5.41	5.39	6.4	7.1
	M4	1.27	7.14	7.12	7.9	8.4
	M5	1.27	7.14	7.12	7.9	8.4

THREAD SIZE AND LENGTH SELECTION DATA

All dimensions are in inches.

UNIFIED	Thread Size	Type	Thread Code	Length "L" +.002 - .005 (Length Code in 32nds of an inch)												
				.312	.375	.437	.500	.562	.625	.687	.750	.812	.875	.937	1.00	1.062
	.112-40 (#4-40)	BSO4	440	10	12	14	16	18	20	22	24	26	28	30	32	34
			6440 ⁽¹⁾	10	12	14	16	18	20	22	24	26	28	30	32	34
	.138-32 (#6-32)	BSO4	632	10	12	14	16	18	20	22	24	26	28	30	32	34
	.164-32 (#8-32)	BSO4	832	10	12	14	16	18	20	22	24	26	28	30	32	34
			032	10	12	14	16	18	20	22	24	26	28	30	32	34
F Dimension Min.				.156	.187	.250			.375							

All dimensions are in millimeters.

METRIC	Thread Size x Pitch	Type	Thread Code	Length "L" +0.05 - 0.13 (Length Code in millimeters)											
				6	8	10	12	14	16	18	20	22	25		
	M3 x 0.5	BSO4	M3	6	8	10	12	14	16	18	20	22	25		
			3.5M3 ⁽¹⁾	6	8	10	12	14	16	18	20	22	25		
	M3.5 x 0.6	BSO4	M3.5	6	8	10	12	14	16	18	20	22	25		
	M4 x 0.7		M4	6	8	10	12	14	16	18	20	22	25		
	M5 x 0.8		M5	6	8	10	12	14	16	18	20	22	25		
F Dimension Min.				3.2	4	5	6.5			9.5					

(1) Standoffs with thread codes 6440, 8632, and 3.5M3 offer greater wall thickness for thread sizes 440, 632, and M3 respectively.

Please contact your local PEM® distributor for availability, minimum quantity, and pricing information.

TYPES SO, SOA, SOS THRU-HOLE THREADED STANDOFFS

GENERAL DIMENSIONAL DATA

All dimensions are in inches.

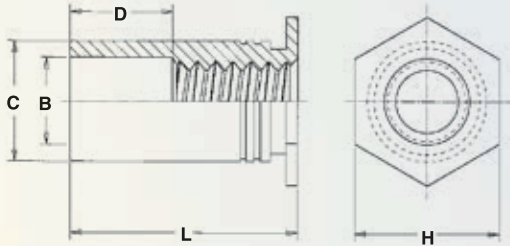

UNIFIED	Thread Code	Min. Sheet Thickness	Hole Size In Sheet +.003 -.000	B Counter-Bore Dia. ±.005	C +.000 -.005	H Nom.	Min. Dist. Hole C/L To Edge
	440	.040	.166	.125	.165	.187	.23
	6440	.040	.213	.125	.212	.250	.27
	632	.040	.213	.156	.212	.250	.27
	8632	.050	.281	.156	.280	.312	.31
	832	.050	.281	.188	.280	.312	.31
	032	.050	.281	.203	.280	.312	.31

All dimensions are in millimeters.

METRIC	Thread Code	Min. Sheet Thickness	Hole Size In Sheet +0.08	B Counter-Bore Dia. ±0.13	C -0.13	H Nom.	Min. Dist. Hole C/L To Edge
	M3	1.02	4.22	3.2	4.2	4.8	6
	3.5M3	1.02	5.41	3.2	5.39	6.4	6.8
	M3.5	1.02	5.41	3.9	5.39	6.4	6.8
	M4	1.27	7.14	4.8	7.12	7.9	8
	M5	1.27	7.14	5.35	7.12	7.9	8

THREAD SIZE AND LENGTH SELECTION DATA

All dimensions are in inches.

UNIFIED	Thread Size	Type			Thread Code	Length "L" +.002 -.005 (Length Code in 32nds of an inch)																		
		Steel	Stainless Steel	Aluminum		.125	.187	.250	.312	.375	.437	.500	.562	.625	.687	.750	.812	.875	.937	1.00	1.062			
	.112-40 (#4-40)	SO	SOS	SOA	440 6440 ⁽¹⁾	4	6	8	10	12	14	16	18	20	22	24	N/A	N/A	N/A	N/A	N/A			
.138-32 (#6-32)	SO	SOS	SOA	632 8632 ⁽¹⁾	4	6	8	10	12	14	16	18	20	22	24	26	28	30	32	34				
.164-32 (#8-32)	SO	SOS	SOA	832	4	6	8	10	12	14	16	18	20	22	24	26	28	30	32	34				
.190-32 (#10-32)				032																				
D Dimension ±.010					None					.187					.312					.437				

All dimensions are in millimeters.

METRIC	Thread Size x Pitch	Type			Thread Code	Length "L" +0.05 -0.13 (Length Code in millimeters)																		
		Steel	Stainless Steel	Aluminum		3	4	6	8	10	12	14	16	18	N/A	N/A	N/A							
	M3 x 0.5	SO	SOS	SOA	M3 3.5M3 ⁽¹⁾	3	4	6	8	10	12	14	16	18	N/A	N/A	N/A							
M3.5 x 0.6	M3.5																							
M4 x 0.7	SO	SOS	SOA	M4	3	4	6	8	10	12	14	16	18	20	22	25								
M5 x 0.8				M5																				
D Dimension ±0.25					None					4					8					11				

(1) Standoffs with thread codes 6440, 8632, and 3.5M3 offer greater wall thickness for thread sizes 440, 632, and M3 respectively. (N/A) Not Available.

Please contact your local PEM® distributor for availability, minimum quantity, and pricing information.

TYPES BSO, BSOA, BSOS BLIND THREADED STANDOFFS

GENERAL DIMENSIONAL DATA

All dimensions are in inches.

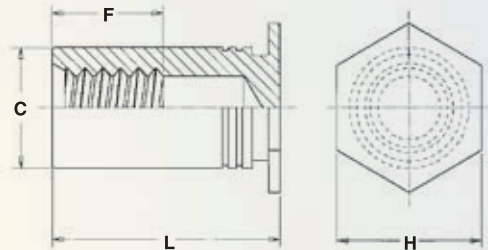

UNIFIED	Thread Code	Min. Sheet Thickness	Hole Size In Sheet +.003 -.000	C +.000 -.005	H Nom.	Min. Dist. Hole C/L To Edge
	440	.040	.166	.165	.187	.23
	6440	.040	.213	.212	.250	.27
	632	.040	.213	.212	.250	.27
	8632	.050	.281	.280	.312	.31
	832	.050	.281	.280	.312	.31
	032	.050	.281	.280	.312	.31

All dimensions are in millimeters.

METRIC	Thread Code	Min. Sheet Thickness	Hole Size In Sheet +0.08	C -0.13	H Nom.	Min. Dist. Hole C/L To Edge
	M3	1.02	4.22	4.2	4.8	6
	3.5M3	1.02	5.41	5.39	6.4	6.8
	M3.5	1.02	5.41	5.39	6.4	6.8
	M4	1.27	7.14	7.12	7.9	8
	M5	1.27	7.14	7.12	7.9	8

THREAD SIZE AND LENGTH SELECTION DATA

All dimensions are in inches.

UNIFIED	Thread Size	Type			Thread Code	Length "L" +.002 -.005 (Length Code in 32nds of an inch)												
		Steel	Stainless Steel	Aluminum		.312	.375	.437	.500	.562	.625	.687	.750	.812	.875	.937	1.00	1.062
	.112-40 (#4-40)	BSO	BSOS	BSOA	440 6440 ⁽¹⁾	10	12	14	16	18	20	22	24	26	28	30	32	34
.138-32 (#6-32)	BSO	BSOS	BSOA	632 8632 ⁽¹⁾	10	12	14	16	18	20	22	24	26	28	30	32	34	
.164-32 (#8-32)	BSO	BSOS	BSOA	832	10	12	14	16	18	20	22	24	26	28	30	32	34	
.190-32 (#10-32)				032														
F Dimension Min.						.156	.187	.250										.375

All dimensions are in millimeters.

METRIC	Thread Size x Pitch	Type			Thread Code	Length "L" +0.05 -0.13 (Length Code in millimeters)										
		Steel	Stainless Steel	Aluminum		6	8	10	12	14	16	18	20	22	25	
	M3 x 0.5	BSO	BSOS	BSOA	M3 3.5M3 ⁽¹⁾	6	8	10	12	14	16	18	20	22	25	
M3.5 x 0.6	M3.5															
M4 x 0.7	BSO	BSOS	BSOA	M4	6	8	10	12	14	16	18	20	22	25		
M5 x 0.8				M5												
F Dimension Min.						3.2	4	5	6.5				9.5			

(1) Standoffs with thread codes 6440, 8632, and 3.5M3 offer greater wall thickness for thread sizes 440, 632, and M3 respectively.

Please contact your local PEM® distributor for availability, minimum quantity, and pricing information.

TYPES SO, SOA, SOS THRU-HOLE UNTHREADED STANDOFFS

GENERAL DIMENSIONAL DATA

All dimensions are in inches.

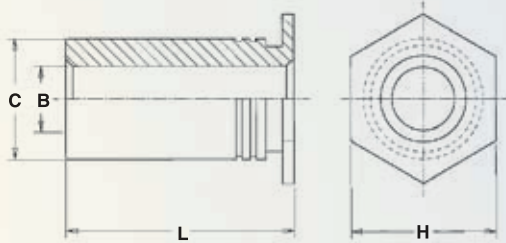

PEM® thru-hole, unthreaded standoffs are available on special order only.

UNIFIED	Thru-hole Code	Min. Sheet Thickness	Hole Size In Sheet +.003 -.000	C +.000 -.005	H Nom.	Min. Dist. Hole C/L To Edge
	4116	.040	.166	.165	.187	.23
	6116	.040	.213	.212	.250	.27
	6143	.040	.213	.212	.250	.27
	8143	.050	.281	.280	.312	.31
	8169	.050	.281	.280	.312	.31
	8194	.050	.281	.280	.312	.31

All dimensions are in millimeters.

METRIC	Thru-hole Code	Min. Sheet Thickness	Hole Size In Sheet +0.08	C -0.13	H Nom.	Min. Dist. Hole C/L To Edge
	43.1	1.02	4.22	4.2	4.8	6
	63.1	1.02	5.41	5.39	6.4	6.8
	63.6	1.02	5.41	5.39	6.4	6.8
	83.6	1.27	7.14	7.12	7.9	8
	84.1	1.27	7.14	7.12	7.9	8
	85.1	1.27	7.14	7.12	7.9	8

THRU-HOLE DIAMETER AND LENGTH SELECTION DATA

All dimensions are in inches.

UNIFIED	B Thru-hole Diameter +.004 -.003	Type			Thru-hole Code	Length "L" +.002 -.005 (Length Code in 32nds of an inch)										
		Steel	Stainless Steel	Aluminum		.125	.187	.250	.312	.375	.437	.500	.562	.625	.687	.750
	.116	SO	SOS	SOA	4116 6116 ⁽¹⁾	4	6	8	10	12	14	16	18	20	22	24
.143	SO	SOS	SOA	6143 8143 ⁽¹⁾	4	6	8	10	12	14	16	18	20	22	24	
.169 .194	SO	SOS	SOA	8169 8194	4	6	8	10	12	14	16	18	20	22	24	

All dimensions are in millimeters.

METRIC	B Thru-hole Diameter +0.1 -0.08	Type			Thru-hole Code	Length "L" +0.05 -0.13 (Length Code in millimeters)										
		Steel	Stainless Steel	Aluminum		3	4	6	8	10	12	14	16	18	20	
	3.1	SO	SOS	SOA	43.1 63.1 ⁽¹⁾	3	4	6	8	10	12	14	16	18	20	
3.6	SO	SOS	SOA	63.6 83.6 ⁽¹⁾	3	4	6	8	10	12	14	16	18	20		
4.1 5.1	SO	SOS	SOA	84.1 85.1	3	4	6	8	10	12	14	16	18	20		

(1) Standoffs with thru-hole codes 6116, 8143, 63.1 and 83.6 offer greater wall thickness for that thru-hole diameter.

Please contact your local PEM® distributor for availability, minimum quantity, and pricing information.

TYPES TSO, TSOS, TSOA THREADED STANDOFFS FOR SHEETS AS THIN AS .025" / 0.63 mm

GENERAL DIMENSIONAL DATA

All dimensions are in inches.

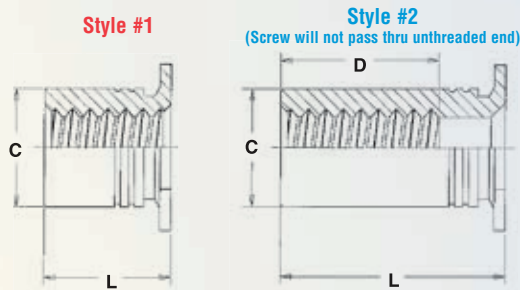

UNIFIED	Thread Code	Min. Sheet Thickness	Hole Size In Sheet +.003 -.000	C +.000 -.005	D Min. Thread Depth	H Nom.	Min. Dist. Hole C/L To Edge
	256	.025	.166	.165	.200	.187	.23
6256	.025	.213	.212	.250		.27	
440	.025	.166	.165	.220	.187	.23	
6440	.025	.213	.212		.250	.27	
632	.025	.213	.212	.270	.250	.27	

All dimensions are in millimeters.

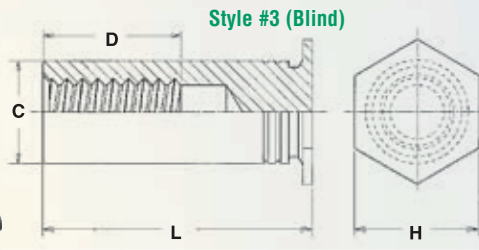

METRIC	Thread Code	Min. Sheet Thickness	Hole Size In Sheet +0.08	C -0.13	D Min. Thread Depth	H Nom.	Min. Dist. Hole C/L To Edge
	M25	0.63	4.22	4.19	5.2	4.8	5.8
6M25	0.63	5.41	5.39	6.4		7.1	
M3	0.63	4.22	4.19	6.2	4.8	5.8	
6M3	0.63	5.41	5.39		6.4	7.1	
M35	0.63	5.41	5.39	7	6.4	7.1	

THREAD SIZE AND LENGTH SELECTION DATA

All dimensions are in inches.

UNIFIED	Thread Size	Type			Thread Code	Length "L" ±.003 For other lengths / thread depth data see chart below.											
		Steel	Stainless Steel	Aluminum		Length Code (Length "L" without decimal point)											
		.090	.125	.187		.250	.312	.375	.437	.500	.562	.625	.687	.750			
.086-56 (#2-56)	TSO	TSOS	TSOA	256	090(1)	125(1)	187(1)	250(1)	312(2)	375(2)	437(3)	500(3)	562(3)	625(3)	687(3)	750(3)	
				6256(4)													
.112-40 (#4-40)	TSO	TSOS	TSOA	440	090(1)	125(1)	187(1)	250(1)	312(2)	375(2)	437(2)	500(3)	562(3)	625(3)	687(3)	750(3)	
				6440(4)													
.138-32 (#6-32)	TSO	TSOS	TSOA	632	N/A	125(1)	187(1)	250(1)	312(1)	375(2)	437(2)	500(2)	562(3)	625(3)	687(3)	750(3)	

All dimensions are in millimeters.

METRIC	Thread Size x Pitch	Type			Thread Code	Length "L" ±0.08 For other lengths / thread depth data see chart below.									
		Steel	Stainless Steel	Aluminum		Length Code (Length "L" without decimal point)									
		2.00	3.00	4.00		6.00	8.00	10.00	12.00	14.00	16.00	18.00	19.00		
M2.5 x 0.45	TSO	TSOS	TSOA	M25	200(1)	300(1)	400(1)	600(1)	800(2)	1000(3)	1200(3)	1400(3)	1600(3)	1800(3)	1900(3)
				6M25(4)											
M3 x 0.5	TSO	TSOS	TSOA	M3	200(1)	300(1)	400(1)	600(1)	800(2)	1000(2)	1200(3)	1400(3)	1600(3)	1800(3)	1900(3)
				6M3(4)											
M3.5 x 0.6	TSO	TSOS	TSOA	M35	N/A	300(1)	400(1)	600(1)	800(1)	1000(2)	1200(2)	1400(3)	1600(3)	1800(3)	1900(3)

(1) Style #1. (2) Style #2. (3) Style #3. (N/A) Not Available

(4) Standoffs with thread codes 6256, 6440, 6M25 and 6M3 offer greater wall thickness for thread sizes 256, 440, M2.5 and M3 respectively.

Please contact your local PEM® distributor for availability, minimum quantity, and pricing information.

LENGTH / STYLE DATA

All dimensions are in inches.

(Length can be specified in .001" increments.)

UNIFIED	Thread Code	Length "L" (Style #1)	Length "L" (Style #2)	Length "L" (Style #3)
	256 6256	.090-.250	.251-.375	.376-.750
440 6440	.090-.280	.281-.450	.451-.750	
632	.120-.350	.351-.540	.541-.750	

All dimensions are in millimeters.

(Length can be specified in .02 mm increments.)

METRIC	Thread Code	Length "L" (Style #1)	Length "L" (Style #2)	Length "L" (Style #3)
	M25 6M25	2.00-6.30	6.32-9.50	9.52-19.00
M3 6M3	2.00-7.50	7.52-11.00	11.02-19.00	
M35	3.00-8.80	8.82-12.80	12.82-19.00	

TYPES DSO AND DSOS THREADED STANDOFFS FOR CLOSE-TO-EDGE APPLICATIONS

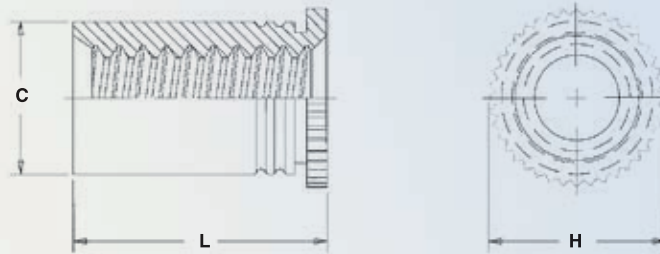

Patented.

All dimensions are in inches.

UNIFIED	Thread Size	Type		Thread Code	Length Code	Sheet Thickness	Hole Size In Sheet +.003 -.000	C Max.	H Nom.	L ⁽¹⁾ +.002 -.005	Min. Dist. Hole C/L To Edge
		Stainless Steel	Steel								
	.112-40 (#4-40)	DSOS	DSO ^{NS}	440	250	.037 - .250	.166	.165	.194	.250	.126
					275					.275	

All dimensions are in millimeters.

METRIC	Thread Size x Pitch	Type		Thread Code	Length Code	Sheet Thickness	Hole Size In Sheet +0.08	C Max.	H Nom.	L ⁽¹⁾ +0.05 -0.13	Min. Dist. Hole C/L To Edge
		Stainless Steel	Steel								
	M3 x 0.5	DSOS	DSO ^{NS}	M3	6.35	0.94 - 6.35	4.2	4.2	4.92	6.35	3.2
					7					7	

(1) Available in other lengths on special order.

(NS) Not Stocked, available on special order.

Please contact your local PEM® distributor for availability, minimum quantity, and pricing information.

MATERIAL & FINISH SPECIFICATIONS

Type	Threads ⁽¹⁾	Fastener Materials					Standard Finishes			For Use In Sheet Hardness:				
	Internal, ANSI B1.1 2B ANSI/ASME B1.13M, 6H	Heat-treated Carbon Steel	Non-heat Treated Carbon Steel	7075-T6 Aluminum	300 Series Stainless Steel	400 Series Stainless Steel	Zinc Per ASTM B 633 SC1 (5µm) Type III, Colorless	Passivated and/or Tested Per ASTM A380	No Finish	88 or less on the Rockwell "B" Scale	80 or less on the Rockwell "B" Scale	70 or less on the Rockwell "B" Scale	60 or less on the Rockwell "B" Scale	50 or less on the Rockwell "B" Scale
SO	•	•					•				•			
SOA	•			•					•					•
SOS	•				•			•			•			
SO4	•					•		•		•				
BSO	•	•					•				•			
BSOA	•			•					•					•
BSOS	•				•			•			•			
BSO4	•					•		•		•				
TSO	•		•				•						•	
TSOS	•				•			•			•			
TSOA	•			•					•					•
DSO	•	•					•				•			
DSOS	•				•			•			•			
Part Number Codes For Finishes							ZI	None	None					

(1) Where applicable.

INSTALLATION

Types DSO and DSOS

1. Provide the correct diameter mounting hole.
2. Do not perform any secondary operations such as deburring.
3. Insert fastener through mounting hole and into anvil as shown in drawing at right.
4. With punch and anvil surfaces parallel, apply only enough squeezing force to embed the standoff's head flush in the sheet.

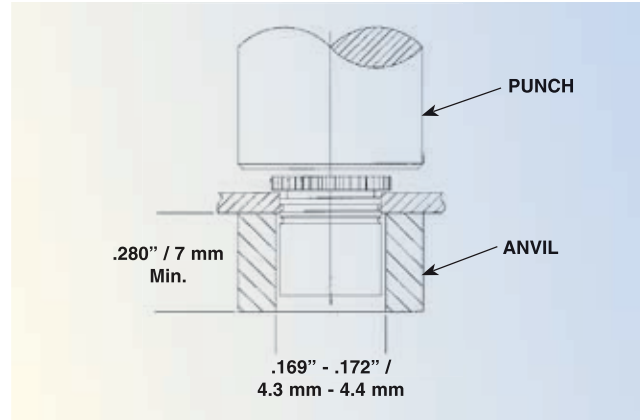

Types SO, SOS, SOA, SO4, BSO, BSOS, BSOA, and BSO4

1. Punch or drill properly sized mounting hole in sheet. Do not perform any secondary operation such as deburring.
2. Insert standoff through mounting hole of sheet and into anvil as shown in drawing.
3. With punch and anvil surfaces parallel, apply only enough squeezing force to embed the standoff's head flush in the sheet. Drawing at right shows suggested tooling for applying these forces.

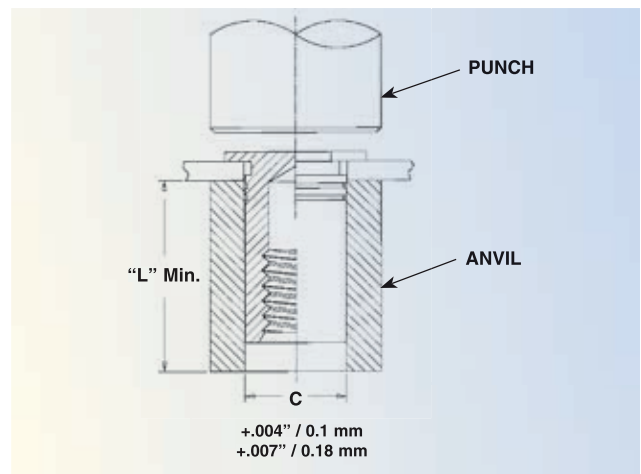

Types TSO, TSOS, and TSOA

1. Punch or drill properly sized mounting hole in sheet. Do not perform any secondary operation such as deburring.
 2. Insert standoff through mounting hole of sheet and into anvil as shown in drawing.
 3. With punch and anvil surfaces parallel, apply only enough squeezing force to embed the standoff's head flush in the sheet. Drawing at right shows required installation anvil for sheet thickness of .025\"/>
- A chamfered anvil is not required for sheets over .032\"/>**

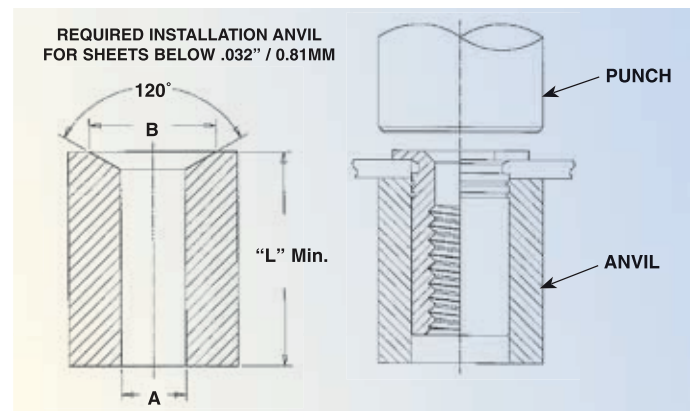

All dimensions are in inches.

Standoff "C" Dimensions	Anvil Dimensions	
	A	B
.165	.167 - .170	.187 - .194
.212	.213 - .216	.250 - .257

All dimensions are in millimeters.

Standoff "C" Dimensions	Anvil Dimensions	
	A	B
4.19	4.24 - 4.32	4.75 - 4.93
5.39	5.41 - 5.49	6.35 - 6.53

PEMSERTER® PRESSES

For best results we recommend using a PEMSERTER® press for either manual or automatic installation of PEM standoffs. For more information on our line of presses call 1-800-523-5321, or check our web site.

PERFORMANCE DATA ⁽¹⁾

Types SO, SOS, SOA, BSO, BSOS, and BSOA

UNIFIED	Thread Code	Standoff Material	Max. Rec. Tightening Torque For Mating Screw (in. lbs.)	Test Sheet Material							
				.060" 5052-H34 Aluminum				.060" Cold-rolled Steel			
				Installation (lbs.)	Pushout (lbs.)	Torque-out (in. lbs.)	Pull-thru ⁽²⁾ (lbs.)	Installation (lbs.)	Pushout (lbs.)	Torque-out (in. lbs.)	Pull-thru ⁽²⁾ (lbs.)
440	Steel	4.75	1100	160	11	280	2200	225	19	330	
	Stainless Steel	3.8	1100	160	11	224	2200	225	19	264	
	Aluminum	2.85	1100	160	11	168	(3)	(3)	(3)	(3)	
6440	Steel	4.75	1700	300	11	280	3300	420	19	330	
	Stainless Steel	3.8	1700	300	11	224	3300	420	19	264	
	Aluminum	2.85	1700	300	11	168	(3)	(3)	(3)	(3)	
632	Steel	8.75	1700	300	25	310	3300	420	35	380	
	Stainless Steel	7	1700	300	25	248	3300	420	35	304	
	Aluminum	5.25	1700	300	25	186	(3)	(3)	(3)	(3)	
8632	Steel	8.75	2400	400	25	310	4000	560	35	380	
	Stainless Steel	7	2400	400	25	248	4000	560	35	304	
	Aluminum	5.25	2400	400	25	186	(3)	(3)	(3)	(3)	
832, 032	Steel	18, 32	2400	400	45	580	4000	560	75	700	
	Stainless Steel	14.4, 25.6	2400	400	45	464	4000	560	75	560	
	Aluminum	11, 19	2400	400	45	348	(3)	(3)	(3)	(3)	

METRIC	Thread Code	Standoff Material	Max. Rec. Tightening Torque For Mating Screw (N•m)	Test Sheet Material							
				1.5 mm 5052-H34 Aluminum				1.5 mm Cold-rolled Steel			
				Installation (kN)	Pushout (N)	Torque-out (N•m)	Pull-thru ⁽²⁾ (N)	Installation (kN)	Pushout (N)	Torque-out (N•m)	Pull-thru ⁽²⁾ (N)
M3	Steel	0.55	4.9	710	1.24	1245	9.8	1000	2.15	1465	
	Stainless Steel	0.44	4.9	710	1.24	996	9.8	1000	2.15	1172	
	Aluminum	0.33	4.9	710	1.24	747	(3)	(3)	(3)	(3)	
3.5M3	Steel	0.55	7.6	1330	1.24	1245	14.7	1860	2.15	1465	
	Stainless Steel	0.44	7.6	1330	1.24	996	14.7	1860	2.15	1172	
	Aluminum	0.33	7.6	1330	1.24	747	(3)	(3)	(3)	(3)	
M3.5	Steel	0.91	7.6	1330	2.82	1375	14.7	1860	3.95	1690	
	Stainless Steel	0.73	7.6	1330	2.82	1100	14.7	1860	3.95	1352	
	Aluminum	0.55	7.6	1330	2.82	825	(3)	(3)	(3)	(3)	
M4, M5	Steel	2, 3.6	10.7	1780	5.08	2575	17.8	2490	8.47	3110	
	Stainless Steel	1.6, 2.88	10.7	1780	5.08	2060	17.8	2490	8.47	2488	
	Aluminum	1.2, 2.16	10.7	1780	5.08	1545	(3)	(3)	(3)	(3)	

Types SO4 and BSO4

UNIFIED	Thread Code	Max. Rec. Tightening Torque For Mating Screw (in. lbs.)	Test Sheet Material			
			.050" 300 Series Stainless Steel			
			Installation (lbs.)	Pushout (lbs.)	Torque-out (in. lbs.)	Pull-thru (lbs.)
440	4.75	5500	336	17	600	
6440	4.75	9500	647	17	680	
632	8.75	9500	647	30	680	
8632	8.75	10500	900	30	1392	
832	18	10500	900	53	1517	
032	32	10500	900	71	1368	

METRIC	Thread Code	Max. Rec. Tightening Torque For Mating Screw (N • m)	Test Sheet Material			
			1.3 mm 300 Series Stainless Steel			
			Installation (kN)	Pushout (N)	Torque-out (N • m)	Pull-thru (N)
M3	0.55	24.5	1493	2.36	2650	
3.5M3	0.55	42.3	2877	2.36	3025	
M3.5	0.91	42.3	2877	3.06	3025	
M4	2	46.7	4003	6.34	645	
M5	3.6	46.7	4003	8.89	6226	

Types TSO, TSOS, and TSOA

Standoff "C" Dimension	Standoff Material	Test Sheet Material											
		.025" / 0.64 mm 5052-H34 Aluminum					.025" / 0.64 mm Cold-rolled Steel						
		Installation		Pushout		Torque-out		Installation		Pushout		Torque-out	
(lbs.)	(kN)	(lbs.)	(N)	(in. lbs.)	(N•m)	(lbs.)	(kN)	(lbs.)	(N)	(in. lbs.)	(N•m)		
.165" / 4.19 mm	Steel	1500	6.7	70	311	6	0.68	2000	8.9	100	445	9	1
	Stainless Steel	1500	6.7	70	311	6	0.68	2000	8.9	100	445	9	1
	Aluminum	1500	6.7	70	311	6	0.68	—	—	—	—	—	—
.212" / 5.38 mm	Steel	1800	8	90	400	11	1.24	2500	11.1	150	667	15	1.7
	Stainless Steel	1800	8	90	400	11	1.24	2500	11.1	150	667	15	1.7
	Aluminum	1800	8	90	400	11	1.24	—	—	—	—	—	—

- (1) The installation, pushout, torque-out and pull-thru values reported are averages when all installation specifications and procedures are followed. Variations in mounting hole size, sheet material and installation procedure will affect this data. Performance testing of this product in your application is recommended. We will be happy to provide samples for this purpose.
- (2) Standoffs installed in sheets thinner than .060"/1.5mm will have pull-thru, pushout, and torque-out values at 80% of tabulated values.
- (3) Not recommended.

PERFORMANCE DATA ⁽¹⁾ (continued)

Types DSO and DSOS

UNIFIED	Thread Code	Max. Rec. Tightening Torque For Mating Screw (in. lbs.)	Test Sheet Material					
			.040" Cold-rolled Steel			.040" 5052-H34 Aluminum		
			Installation (lbs.)	Pushout (lbs.)	Torque-out (in. lbs.)	Installation (lbs.)	Pushout (lbs.)	Torque-out (in. lbs.)
440	3.8	1300	75	10	1000	50	10	

METRIC	Thread Code	Max. Rec. Tightening Torque For Mating Screw (N • m)	Test Sheet Material					
			1 mm Cold-rolled Steel			1 mm 5052-H34 Aluminum		
			Installation (kN)	Pushout (N)	Torque-out (N • m)	Installation (kN)	Pushout (N)	Torque-out (N • m)
M3	0.44	5.8	334	1.1	4.5	223	1.1	

(1) The installation, pushout, and torque-out values reported are averages when all installation specifications and procedures are followed. Variations in mounting hole size, sheet material and installation procedure will affect this data. Performance testing of this product in your application is recommended. We will be happy to provide samples for this purpose.

RoHS compliance information can be found on our website.

Specifications subject to change without notice.
Check our website for the most current version of this bulletin.

PennEngineering®



North America: Danboro, PA 18916 USA • E-mail: info@pemnet.com • Tel: +1-215-766-8853 • Fax: +1-215-766-0143 • 800-237-4736 (USA Only)

U.K. And Europe: Doncaster, England • E-mail: uk@pemnet.com Tel: +44 (0)1302 765700 • Fax: +44 (0)1302 367580

Asia/Pacific: Singapore • E-mail: singapore@pemnet.com • Tel: +65-6-745-0660 • Fax: +65-6-745-2400
Shanghai, China • E-mail: china@pemnet.com • Tel: +86-21-5868-3688 • Fax: +86-21-5868-3988

Visit our PEMNET™ Resource Center at www.pemnet.com

CAGE-46384